

NOTE: REMOVE EXISTING TRENCH BACKFILL AND REPLACE WITH 3" MINUS A1_a MATERIAL. COMPACT IN 8-INCH LIFTS OR AS REQUIRED BY THE GEOTECHNICAL REPORT.

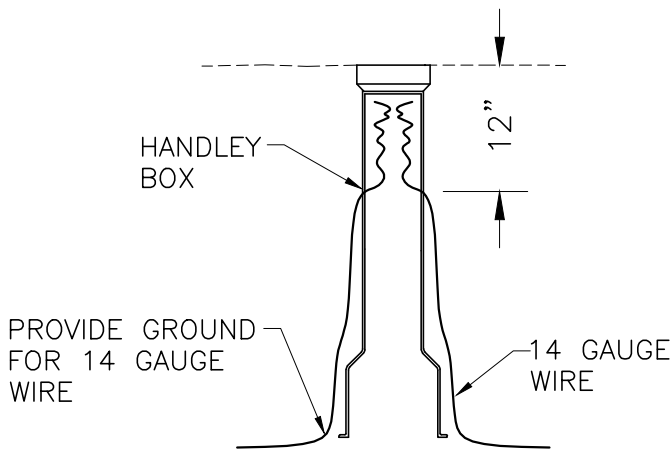

PROVIDE HANDLEY BOX (OR APPROVED EQUAL) FOR TRACER WIRE WHERE VALVE BOX SPACING EXCEEDS 400'. BRING TRACER WIRE INTO BOX A MINIMUM OF 12" BELOW CAP AND PROVIDE 30" OF COILED WIRE. TRACER WIRE SHALL BE CHECKED FOR CONTINUITY PRIOR TO ACCEPTANCE.

**INSULATED COPPER WIRE
AT HANDLEY AND VALVE
BOXES**

**TYPICAL TRENCH
DETAIL**